

# ELIMINATE TRAILER SWAY



## SEE WHAT OTHERS HAVE SAID ABOUT THE ADDED SAFETY OF EQUAL-I-ZER'S 4 POINT SWAY CONTROL.

"It is refreshing to find a product that lives up to its claims, is so reasonably priced and backed up by such good customer service."

*Bob Ellenberg (California)*



"Before using your hitch, the sway was unsafe at any speed or road condition. After installing the Equal-i-zer hitch, the sway was non-existent and I now have a feeling of control over the trailer instead of the trailer controlling the tow vehicle."

*Bob Jazemski (California)*

"This hitching system is the best bargain on the market and is superior to anything anywhere near its cost."

*James Cayer (Rhode Island)*

"I encountered heavy wind, rain and trucks flying by me. Through these conditions your hitch lived up to all your claims and all my expectations. I am very picky about all the equipment I use and I was very impressed. I have to say I am very meticulous and safe and I'm convinced."

*Guy Neuls (New Jersey)*

THE ORIGINAL  
**Equal-i-zer**<sup>®</sup>  
SWAY CONTROL HITCH

When you tow a travel trailer, sway and other control problems can hinder your trip. Loss of control, regardless of how temporary, adds stress to the driver and passengers. This stress can ruin a family vacation or getaway. Big rigs and cross winds can create a scary situation even for seasoned drivers. Equal-i-zer brand hitch eliminates these stressful towing hazards. The Equal-i-zer's unique two in one design eliminates trailer sway and provides proper weight distribution.

## SWAY CONTROL

Equal-i-zer brand hitch eliminates trailer sway by preventing sway before it starts. Equal-i-zer's 4 point sway control is a combination of 4 friction points that work together to stop trailer sway. 4 point sway control is superior to "add-on" friction bars that are used with conventional or chain-style weight distribution hitches.



Don't just dampen trailer sway with an "add-on" sway device. Eliminate it with Equal-i-zer's proven system of built-in trailer sway control.

## WEIGHT DISTRIBUTION

Without weight distribution the weight of the trailer pushes the rear of the tow vehicle down. Hazards associated with driving a trailer without weight distribution include loss of steering control, braking difficulties, and hitch dragging. Equal-i-zer brand hitch combats such hazards by providing proper weight distribution. With Equal-i-zer the trailers weight is safely and easily distributed to all axles of the vehicle.

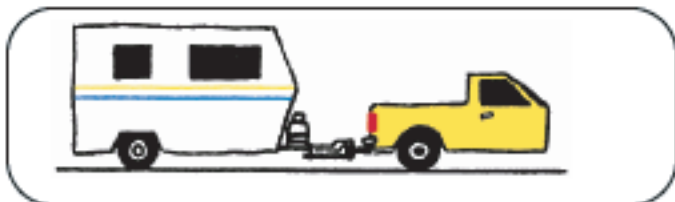

With Equal-i-zer the truck and trailer are level

## EASY TO USE

Equal-i-zer eliminates the need for add-on sway systems associated with chain-style hitches. No more sway bar hassles such as loosening before backing, removing in wet weather, and restricted turning radius. That also means less time and hassle to hook-up. Hook-up is a breeze with Equal-i-zer's rigid trailer attachments. Using the trailer's jack and/or optional snap up lever, the arms are lifted into place on the trailer brackets. This design also eliminates the chance of the chains snapping back at you.

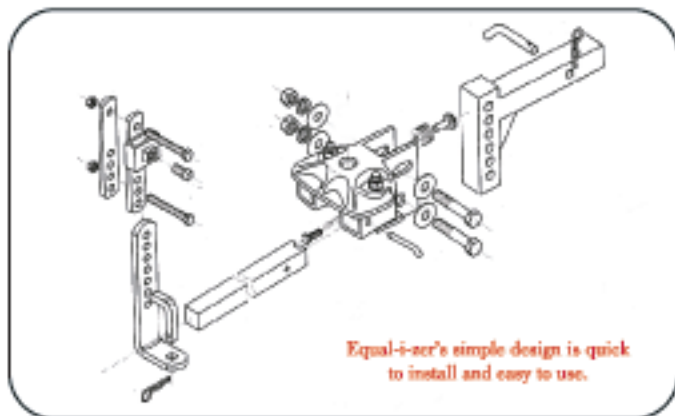

## QUALITY CONSTRUCTION

A lifetime warranty is easy to offer because Equal-i-zer is designed for strength and durability. Critical hitch components are constructed from American made chrome molly steel. Chrome molly steel is known for its increased tensile strength, hardness, resistance to wear and its ability to absorb energy. The shaped components of Equal-i-zer are forged rather than cast. The tighter molecular structure of a forging provides increased strength and resistance to wear. Manufacturing Equal-i-zer is all we do so our production process focuses on quality. We guarantee Equal-i-zer to be free of manufacturer defects for as long as you own your hitch. Which means we will be behind you for a long, long time.

THE ORIGINAL  
**Equal-i-zer**  
SWAY CONTROL HITCH

Lindon Hitch, Inc.  
Lindon, Utah  
800-478-5578

# How does 4 POINT SWAY CONTROL work?

## 2 ROTATIONAL FRICTION SWAY CONTROLS

Rotational friction stops side to side sway before it starts. The friction sway control is activated by downward pressure from the trailer tongue and upward pressure on the spring arms. The spring arms distribute trailer tongue weight and link the rotational sway control to the sway control brackets. The rigidity of the sway control brackets allow the dual rotational friction sway control to effectively hold the trailer in line behind the tow vehicle and stop sway before it starts.



## 2 SWAY CONTROL BRACKETS

Innovative rigid trailer attachments serve two purposes. First, they work in conjunction with the rotational friction sway controls to eliminate trailer sway. Second, the forward and back friction of the hitch arm on the bracket serves as a secondary sway control system. The sway control brackets work much like 2 "add-on" sway bars, but with more sway stopping pressure and less hassle. The sway control brackets are the innovative link that make Equal-i-zer's 4 point sway control system so effective at protecting your most precious investments.



NOTE: Trailer hitch ball is sold separately.

Lindon Hitch, Inc.  
475 N. State St.  
Lindon, Utah 84042  
800-478-5578  
801-785-5182 (fax)  
[www.equalizerhitch.com](http://www.equalizerhitch.com)